

NOTICE

This document contains proprietary information protected by copyright, and this User's Manual and all the accompanying hardware are copyrighted. All rights are reserved. No part of this document may be photocopied or reproduced by mechanical, electronic, or other means in any form.

The manufacturer reserves the right to make changes to the hardware and Users Manual content without obligation to notify any person or organization of the revision or change.

LIMITED WARRANTY

Partners Data Systems, Inc. (PDS) warrants to the original purchaser that this product is free from any defective material and/or workmanship and agrees to repair or replace any part of this product which proves defective by reason of improper workmanship or material for a period of one year from date of original purchase and subject to the conditions set forth below.

If this product does not perform as described herein, owner's sole remedy shall be repair or replacement as provided below.

In no event will PDS be liable for damages, lost data, lost revenue, lost wages, lost savings or any other incidental or consequential damages arising from purchase, use, or inability to use this product, even if PDS has been advised of the possibility of such damages.

For warranty support, any defective product should be returned (PDS), by first obtaining an RMA (Return Material Authorization) number. Be prepared to supply a copy of the sales invoice, and a detailed description of the problem you are experiencing. The product serial number should be intact.

No express or implied warranty is made for any PDS product damaged by accidents, misuse, abuse, natural or personal disaster or unauthorized modification. PDS reserves the right to make modifications and enhancements to its products without incurring obligation of any kind.

First Edition / 010102

All brand and product names are the trademarks of their respective owners.

Copyright © 2002-2003 by Partners Data Systems, Inc.

All rights reserved. Printed in the U.S.A.

PARTNERS DATA SYSTEMS, INC.

3663 Via Mercado

La Mesa, CA 91941-8316 • U.S.A

Telephone: (619)-415-2000 • Fax: (619) 415-2001

Contents

Chapter 1. INTRODUCTION

1.1	RAID CONCEPTS	6
1.1.1	RAID Levels	6
1.1.1.1	Striping (RAID 0)	6
1.1.1.2	Mirroring(RAID 1).....	7
1.1.1.3	Striping with Dedicated Parity (RAID 3) .	7
1.1.1.4	Striping with Interspersed Parity (RAID 5) .	8
1.1.1.5	Stripping with Mirroring (RAID 0+1)	8
1.1.2	Comparison Table	9
1.2	FEATURE HIGHLIGHTS.....	9

Chapter 2. GETTING STARTED

2.1	UNPACKING & CHECKING THE EQUIPMENT	10
2.2	IDENTIFYING PARTS OF THE LC8	10
2.2.1	Front View	11
2.2.2	Rear View	13
2.3	SPACE REQUIREMENTS	13
2.4	SYSTEM CONNECTING	14
2.5	INSTALLING THE DISK	14
2.5.1	Removing the disk cartridge	14
2.5.2	Installing the disk	15
2.5.3	Installing the disk cartridge	15
2.6	POWER ON AND SELF-DIAGNOSTIC	16
2.6.1	Powering on the system	16
2.6.2	Self-Diagnostic mode	16

Chapter 3. CONFIGURING YOUR RAID

3.1	FROM CONTROL PANEL & LCD ON FRONT PANEL	16
3.2	FROM ANSI TERMINAL VIA MONITOR UTILITY.....	17
3.2.1	Monitor Utility	17
3.2.2	Key Definitions Under ANSI/VT-100 Terminal	17
3.2.3	Connecting Terminals	18
3.2.3.1	Communication Ports Settings	18
3.2.3.2	Terminal Access	18
3.2.3.3	Using The Monitor Utility	18
3.2.3.4	Running Configuration Mode	19
3.3	CONFIGURING RAID	19
3.3.1	Quick Setup	19
3.3.1.1	Defaults value of Quick Setup	20
3.3.2	Customizing Setup	20
3.3.2.1	RAID Params menu	21
3.3.2.2	SCSI/FIBRE Params menu	22
3.3.2.3	RS232 Params menu	24
3.3.2.4	SYSTEM Params menu	25

3.3.2.5	NVRAM	26
3.3.2.6	RAID Funcs menu	26
3.4	SAMPLES	28
3.4.1	Sample 1. RAID 5 with Hot Spare Disk	28
3.4.2	Sample 2. Change the Password of your RAID	29

Chapter 4. HOT SWAP COMPONENTS

4.1	SWAPPING THE DISK	31
4.2	SWAPPING THE POWER SUPPLY MODULE	31
4.3	SWAPPING THE COOLING FAN	32
4.3.1	System Cooling Fans	32

Chapter 5. ADVANCE SETUP

5.1	UPDATING FIRMWARE	33
-----	-------------------------	----

APPENDIX A. TROUBLESHOOTING & ERROR MESSAGES

A.1	TROUBLESHOOTING	34
A.2	ERROR MESSAGES	37

APPENDIX B. TECHNICAL SPECIFICATION	39
--	----

APPENDIX C. CONNECTORS	40
-------------------------------------	----

APPENDIX D. GLOSSARY	42
-----------------------------------	----

APPENDIX E. CREATING TWO LUNs.....	44
---	----

APPENDIX F. RAID TO HOST CONNECTIVITY	45
---	----



DO NOT place the *SurfRAID LC8* on uneven or unstable work surfaces. Seek servicing if the casing has been damaged.



DO NOT place or drop objects on top of the *SurfRAID LC8* and do not shove any foreign objects into it.



DO NOT expose *SurfRAID LC8* to liquids, rain or moisture.

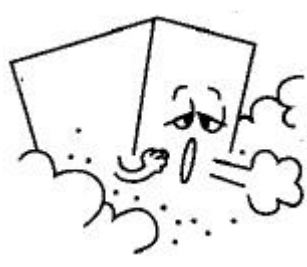

DO NOT expose *SurfRAID LC8* to dirty or dusty environments.



DO NOT expose *SurfRAID LC8* to magnetic fields.

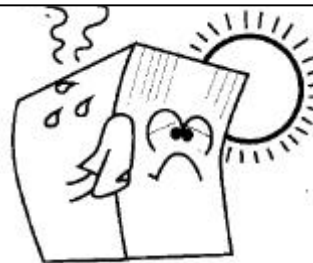

DO NOT expose *SurfRAID LC8* to extreme temperatures or to direct sunlight.

About your User's Manual

Welcome to your *SurfRAID LC8* Redundant Array of Independent Disks System User's Manual. This manual covers everything you need to know in learning how to install or configure your RAID system. This manual also assumes that you know the basic concepts of RAID technology.

This manual is divided into five chapters and four appendixes.

- Chapter 1. **INTRODUCTION**
 Gives introduction on RAID technology and *SurfRAID LC8* features.
- Chapter 2. **GETTING STARTED**
 Helps user to identify parts of the *SurfRAID LC8* and prepare the Hardware for configuration.
- Chapter 3. **CONFIGURING YOUR RAID**
 Quick Setup
 Provides an easy way to setup your *SurfRAID LC8*.
 Customizing Setup
 Provides step-by-step instructions to help you to setup or re-configure your *SurfRAID LC8*.
- Chapter 4. **HOT SWAP COMPONENTS**
 Describes all hot swap modules on *SurfRAID LC8* and provides a detailed procedure to replace them.
- Chapter 5. **ADVANCED SETUP**
 Updating Firmware
 Provides step-by-step instructions to help you to update the firmware to the latest version.
- Appendix A. **TROUBLE SHOOTING AND ERROR MESSAGES**
- Appendix B. **TECHNICAL SPECIFICATION**
- Appendix C. **CONNECTORS**
- Appendix D. **GLOSSARY**
- Appendix E. **CREATING TWO LUNs**
- Appendix F. **FIBRE RAID TO HOST CONNECTIVITY**

CHAPTER 1. INTRODUCTION

RAID CONCEPTS

The need to ensure continuous access to critical computer data is essential today in the highly competitive business environment. Data loss and server downtime caused by drive failure often results a lost in productivity, decreased profitability and can make the difference between success and failure. RAID (Redundant Array of Independent Drives) addresses these problems. The benefits of RAID include:

Availability

Provides fault-tolerance by mirroring or parity operation. If any single disk drive in the RAID fails, the RAID still continues to function without loss of data.

Capacity

Provides disk spanning by weaving all connected drives into one single volume.

Performance

Increases disk access speed by braking data into several blocks when reading / writing to several drives in parallel. With RAID, storage speed increases as more drives are added.

1.1.1 RAID LEVELS

The SurfRAID LC8 supports RAID Levels 0, 1, 3, 5 & 0+1. Each RAID level offers a different performance, functionality and fault tolerance, depending on the application that will be used. The following is a brief explanation of each RAID level. Before configuring the SurfRAID LC8 be sure to know which RAID level is best suited for your application.

1.1.1.1 Striping (RAID 0)

Striping refers to the storing of data across multiple drives in a drive group. If there are three drives in a drive group then the subsequent data will be stored across all three drives. This creates a very high performance virtual disk with the capacity equal to the combined capacity of the installed disks. RAID Level 0 provides high availability and very high performances for both read and write operations. However, no redundant parity is generated for protection against disk failure.

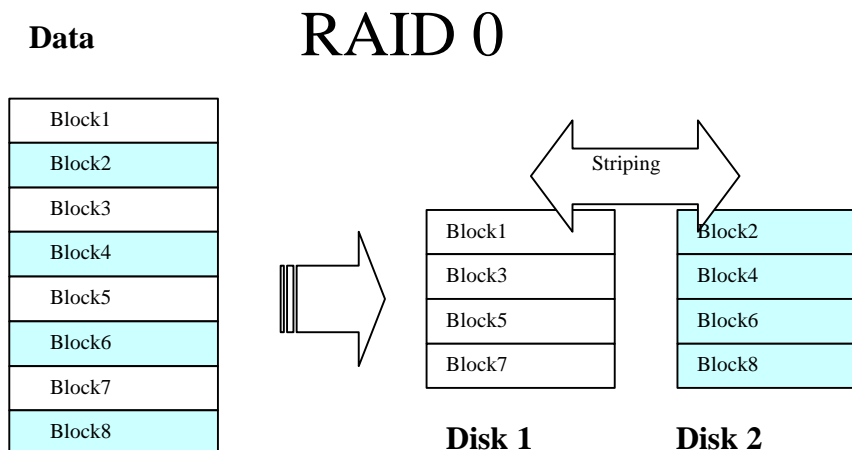

1.1.1.2 Mirroring (RAID 1)

Mirroring refers to the replication of data on two or more drives. Each drive contains a mirror image of the data on the primary drive. Virtual disk space equals to capacity of the smallest installed disk drive. Mirroring causes operational overhead resulting in lower performance for write operations, however it does provide the highest data reliability among RAID Levels 0 to 5 with very high performance for read intensive operations.

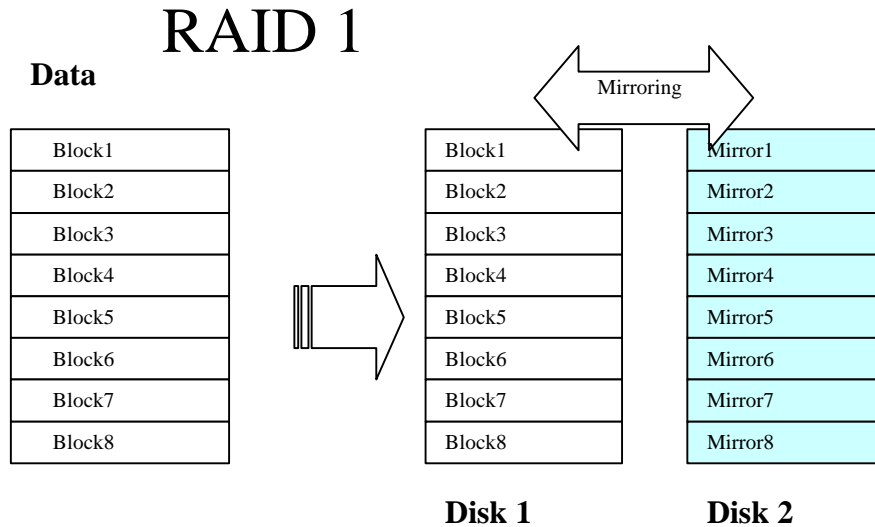

1.1.1.3 Striping with Dedicated Parity (RAID 3)

Performs Block Striping with Dedicated Parity. One drive member is dedicated to storing the parity data. When a drive member fails, the controller can recover/regenerate the lost data of the failed drive from the dedicated parity drive.

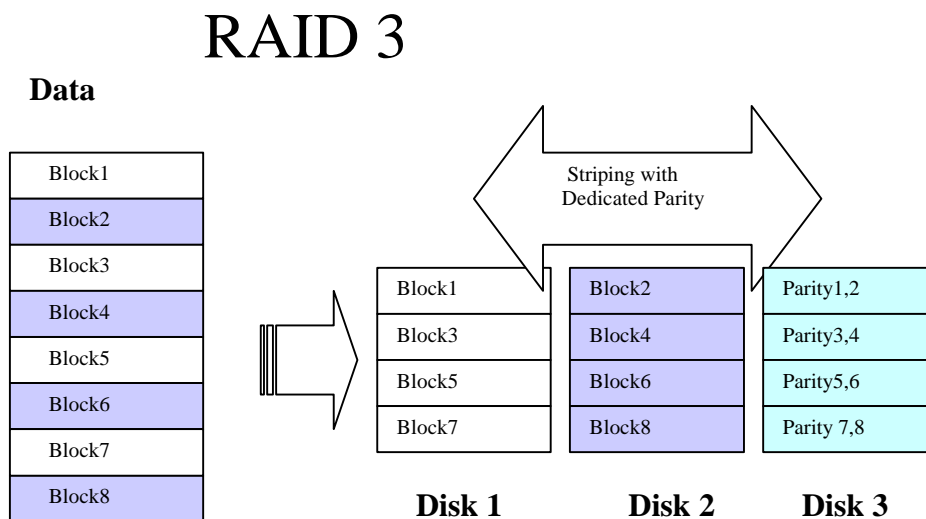

1.1.1.4 Striping with Interspersed Parity (RAID 5)

Striping with Parity is a method of storing data striped across multiple drives like RAID 0 but with parity (redundant data calculated by XOR logic used to reproduce data in case of lost data) also striped across the drives. RAID Level 5, which offers a very high data redundancy, availability and performance.

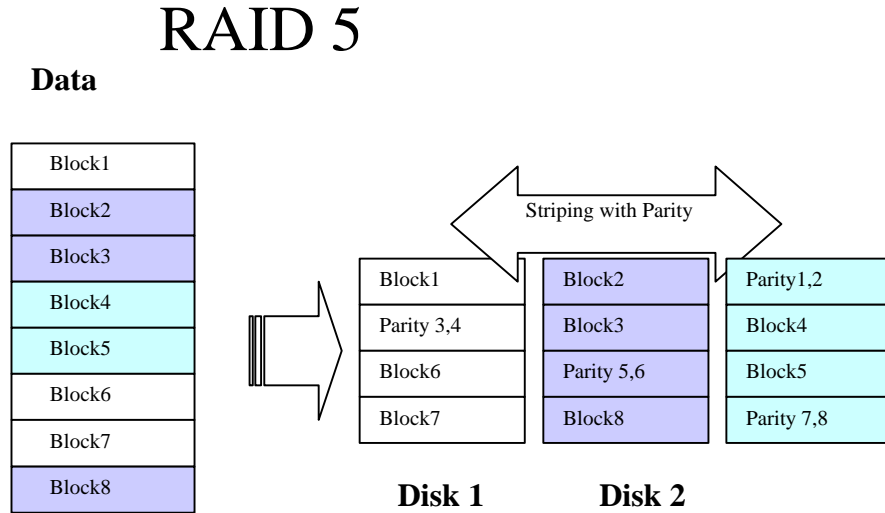

1.1.1.5 Striping with Mirroring (RAID 0+1)

This RAID level is a combination of RAID 0 (Striping) and RAID 1 (mirroring), it contains both features of these arrays-security and sequential performance. Sometimes it is referred to as RAID 10.

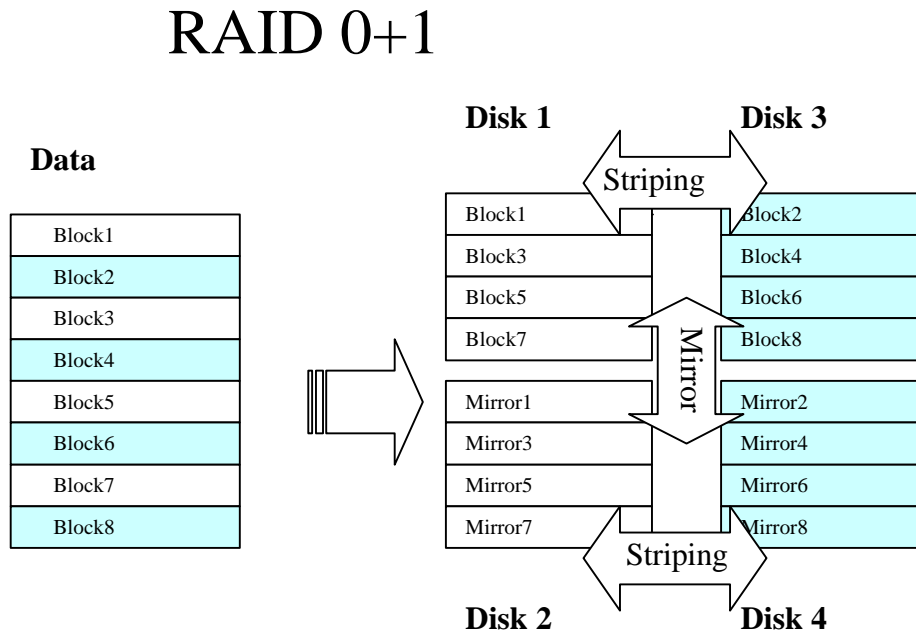

1.1.2. RAID LEVEL COMPARISON TABLE

RAID Level	Name	Description	Minimum Drives Required	Available disk Number.	Data Availability
0	Data Striping	* The Data is broken down into strips and striped across the member disks of the array. * Provides no redundancy.	2	[N]	Low
1	Mirrored Disks	* Provides redundancy by writing identical data to each member disk of the array.	2	[1]	Very High
3	Striping with a dedicated parity disk	* Provides redundancy by writing parity to a dedicated Disk.	3	[N-1]	High
5	Independent Drives With Spread Parity	* Provides redundancy by distributing parity across some or all of an array's member disks.	3	[N-1]	High
0+1	Data Striping with Mirrored	* This RAID Level is combination of RAID 0 (striping) & RAID 1 (Mirrored)..	4	[N/2]	Very High

1.2 FEATURE HIGHLIGHTS

The SurfRAID LC8 is designed to meet today's demand of higher storage solutions for the emerging needs of databases, e-mail, web servers and imaging systems. It provides a maximum data protection and exceptional performance in a storage subsystem. Target usage ranges are set from small business to departmental and corporate server needs. The SurfRAID LC8 is designed for easy integration, smooth data expansion and server migration.

The SurfRAID LC8 supports the following features:

- * Host System independent
- * Operating System independent
- * High performance processor
- * Superior Array Management Firmware
- * Advanced PCI bus architecture
- * 256MB of cache
- * Support for RAID Levels 0, 1,3, 5 and 0+1
- * Dual Ultra-160 SCSI Host Interconnect Support → LC8.160
- * Dual Loop of 2Gb/sec Fibre Channel → LC8.200
- * Redundant and Hot Swappable Fan, Power and Drives.
- * Hot Swap, Hot Spare and Automatic Drive Rebuild Support

- * Programmable Page and FAX event notification
- * Remote monitoring through terminal
- * Two load-sharing hot swappable redundant power modules which support the Power Factor Correction function

CHAPTER 2. GETTING STARTED

2.1 UNPACKING & CHECKING THE EQUIPMENT

Before unpacking the SurfRAID LC8, prepare a clean, stable surface for the contents of your SurfRAID LC8 shipping container. Altogether, you should find the following items in the package:



Remove all the items from the container. If anything is missing or broken, please inform Partners. Our advice is to keep the packaging – if you ever need to ship your SurfRAID LC8 out for service, you will need the shipping container.

2.2 IDENTIFYING PARTS OF THE SurfRAID LC8

The illustrations below identify the various features of the SurfRAID LC8. Get yourself familiar with these terms as they will help you when you read further in the following sections.

2.2.1 FRONT VIEW SurfRAID LC8

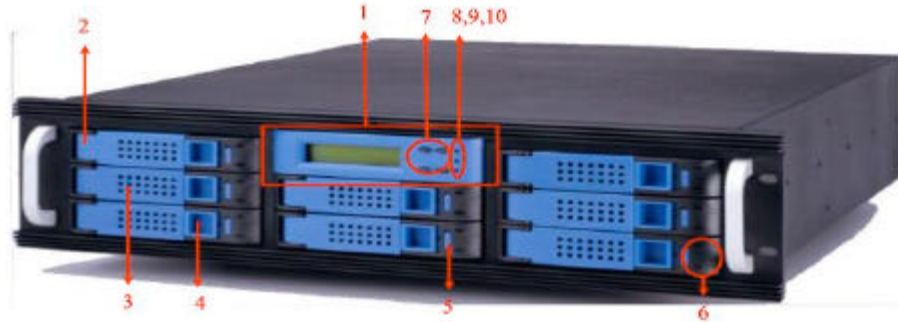

1. LCD Display Panel.

The front panel LCD continuously displays the status of the SurfRAID LC8. The following is an example.

```
SurfRAID LC8
00000000 □
```

Field	Description														
SurfRAID LC8 00000000	The model of SurfRAID LC8														
SurfRAID LC8 00000000	The model of SurfRAID LC8														
00000000	Total eight disks channel status. Other symbols are:														
	<table border="1"> <thead> <tr> <th>Symb ol</th> <th>Description</th> </tr> </thead> <tbody> <tr> <td>X</td> <td>Disk is not installed</td> </tr> <tr> <td>A</td> <td>Disk is being Added</td> </tr> <tr> <td>I</td> <td>Identifying Disk.</td> </tr> <tr> <td>O</td> <td>Disk is On-line</td> </tr> <tr> <td>S</td> <td>Disk is a Spare disk</td> </tr> <tr> <td>R</td> <td>Disk is Removed</td> </tr> </tbody> </table>	Symb ol	Description	X	Disk is not installed	A	Disk is being Added	I	Identifying Disk.	O	Disk is On-line	S	Disk is a Spare disk	R	Disk is Removed
Symb ol	Description														
X	Disk is not installed														
A	Disk is being Added														
I	Identifying Disk.														
O	Disk is On-line														
S	Disk is a Spare disk														
R	Disk is Removed														

When the “[Enter]” button is pressed in operation mode, the SurfRAID LC8 will enter Configuration Mode. Note: During Configuration Mode if no button is pressed within 3 minutes (180 seconds), the SurfRAID LC8 will automatically switch back to Operation Mode.

2. **Disk Cartridges**
3. **Cartridge Handle**
4. **Release-Button**



5. **Latch**

LOCK	
------	--



UNLOCK	
--------	--

6. **HDD status LED Indicator**



LED	Colors	Indicate
	Green	HDD On Line
	Amber	HDD Access
?	Red	HDD Error

7. **Function keys. (ENT, ESC,)**



Keys	Descriptions
------	--------------



Up Arrow	To scroll upward through the menu items
Down Arrow	To scroll downward through the menu items
(ENT) Enter	To confirm a selected item
(ESC) ESC	To exit a sub-menu and return to previous menu.

8.  **Power On Indicator (green).**



9. **Power Fail Indicator (Red)**

10.  **Host System Access Indicator (Yellow).**

2.2.2 REAR VIEW

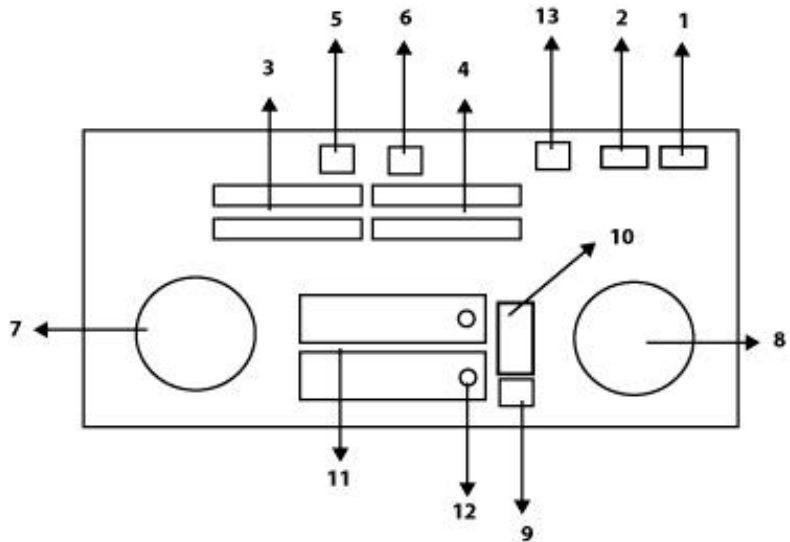

1. RS232 Port (For Terminal)
2. Modem Port
- LC8.160: 3. Host SCSI Channel Port
4. Second Host SCSI Channel Port
- OR
- LC8.200: 5. 1st Fibre Channel Loop
6. 2nd Fibre Channel Loop
7. System Cooling Module 1.
8. System Cooling Module 2.
9. Power Supply “Alarm” Reset Button.
10. Power Plug.
11. Power Supplies
12. Power Indicator LED on Module.
13. Power Switch

2.3 SPACE REQUIREMENT

When selecting a location for your system, be sure to allow space for the system. The system has vents around system that require a minimum of 3 inches of unobstructed space for airflow. Openings in the equipment should be blocked, or there may be reliability problems with your system. A system product should never be placed around a radiator or heat register.

2.4 SYSTEM CONNECTING

Connect all cables and power cord as shown below:

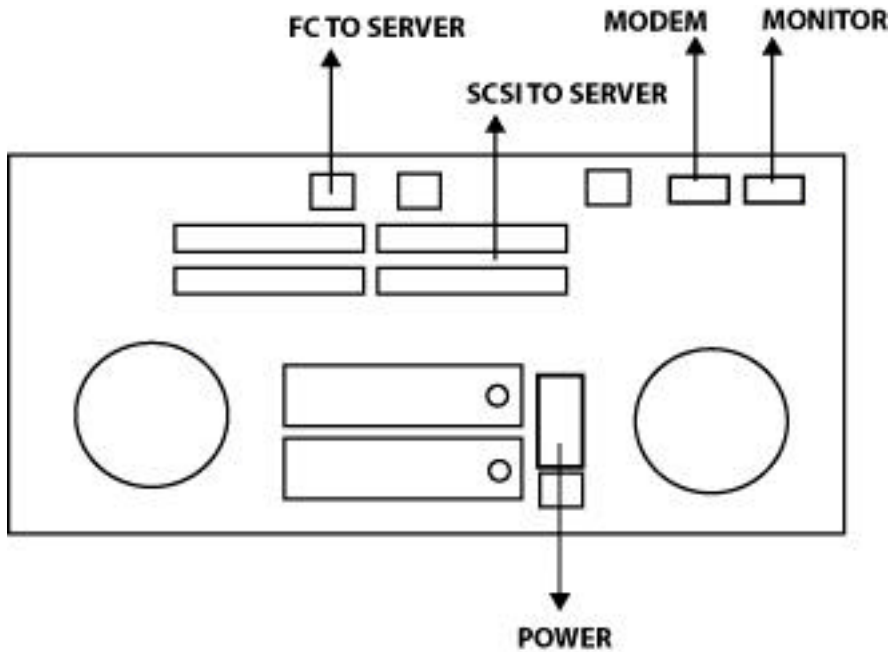

WARNING: Make sure that all the devices are powered off before connecting or removing cables to prevent power spikes which can damage technical components.

2.5 Installing Disk Cartridge

The SurfRAID LC8 includes eight removable disk cartridges. The following sections describe how to install disks into SurfRAID LC8 subsystems.

2.5.1 Removing the disk cartridge

1. Slide the latch to unlock position.
2. Release the cartridge handle by sliding the release-button.
NOTE: If the SurfRAID LC8 is on line, the disk LED will turn from green to Red to indicate the disk is powered down.
3. Lift the handle to disengage the disk cartridge from the slot
4. Gently pull the disk cartridge out of the slot

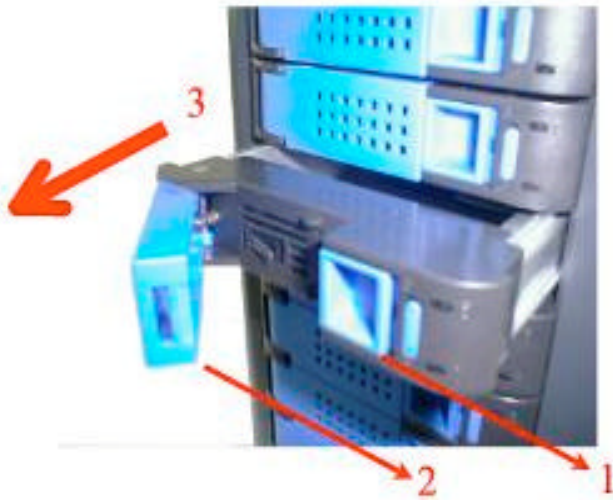

2.5.2 Installing the disk

1. Insert HDD into the cartridge.
2. Connect the flat cable to the disk. Verify pin 1 (also designated by the color strip) of the cable is aligned with pin 1 of the disk connector.
3. Connect the power cord to the disk drives power connector.
5. Fasten the screws to mount the drive in the disk cartridge. Make sure the drive is properly tightened

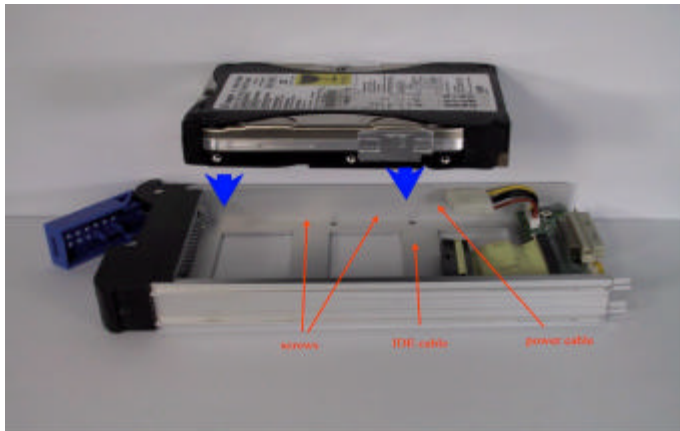

2.5.3 Installing the disk cartridge

1. Make sure the handle is up and the latch is on the position of unlock.
2. Gently slide the disk cartridge to the end of the slot then firmly push until the face plate of the disk cartridge is flush with the front panel of the SurfRAID LC8.
3. Push down the handle to secure the disk cartridge into the SurfRAID LC8
NOTE: If the SurfRAID LC8 is powered up, the disk LED will turn from red to green to indicate that power has been applied to the disk drawer.
4. Slide the latch to the position of lock.

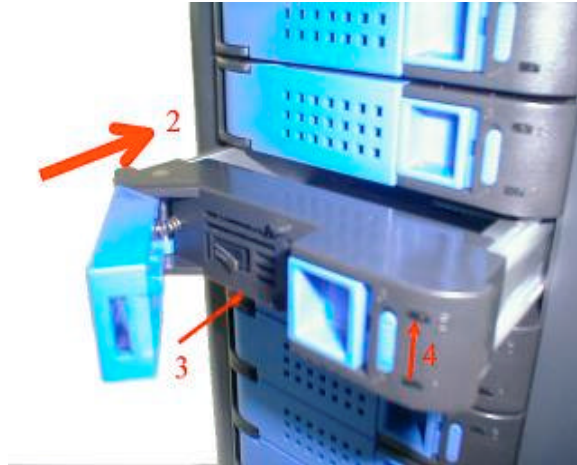

2.6 POWER ON AND SELF-DIAGNOSTIC

Before you start,

The system should be at a room temperature before you power it up. If the equipment was shipped when outdoor temperature were significantly above or below room temperature, it is best to wait several hours before powering on the system.

2.6.1 Powering on the system

Turn on the power switch from rear panel.

2.6.2 Self-Diagnostic Mode

To ensure flawless operation, SurfRAID LC8 has a built-in self-diagnostic utility. Self-diagnostic Mode occurs automatically upon power up or after reset. During this mode, all components are tested, and any potential problems will be reported.

The Self-Diagnostic Mode runs three major diagnostic tests. The first diagnostic includes testing of the CPU and supporting core logic chips, the internal bus, memory, SCSI controller, enhanced IDE controllers and RS-232 controllers. The second diagnostic tests for the presence of disks on each individual disk channel. It also checks the functionality of the disk found. The final diagnostic tests the functionality of the RAID.

CHAPTER 3. CONFIGURING YOUR RAID

3.1 From the control panel on Front

The Control Panel

The SurfRAID LC8 Control Panel consists of a two line by 16-character LCD display, two LED indicators, four push button switches, and a reset button. It provides a way to configure and monitor the operation of the SurfRAID LC8.

A. Function Keys Definitions

Keys	Descriptions
(↑) Up Arrow	To scroll upward through the menu items
(↓) Down Arrow	To scroll downward through the menu items
(ENT) Enter	To confirm a selected item
(ESC) ESC	To exit a sub-menu and return to previous menu.

B. LCD Display (Configuring Mode)

Change to Configuration mode by following steps:

LCD Display	Control Panel	Description
SurfRAID LC8 00000000	Enter	Go to Configuration mode
PASSWORD 0 □ □ □ □ □ □ □ □	Press “Enter” for 8 times	Defaults Password is “00000000”
Main Menu 0 Quick Setup	Enter	Go to “main menu”

3.2 From ANSI Terminal Via Monitor Utility

3.2.1 Monitor Utility

The SurfRAID LC8 control panel allows exploration of all configurable features. However, the small form factor of the control panel only allows a small LCD display output. A limited amount of information can be displayed at a given time on the LCD display.

The monitor utility displays all information on a larger terminal screen via a serial interface. The monitor utility is identical to the LCD display, where it displays the basic self-diagnostic, operation, and configuration information. However, it allows the Configuration Menu to be displayed using a graphical user interface. Additionally, it displays more verbose error, warning and status messages, impractical to display on the front control panel LCD.

NOTE: The Monitor Utility via the RS-232 interface and the front control panel cannot be used at the same time. When one is active, access to the other is disabled.

3.2.2 Key Definitions under ANSI/VT-100 Terminal

The SurfRAID LC8 supports VT100 terminal and standard ANSI Terminal emulation. The following keys are supported:

A - use to scroll upward through the menu items

Z - use to scroll downward through the menu items

Enter - use to select a menu item, open a sub-menu, and use to select a value

ESC - use to exit a sub-menu and return to the previous menu

The rest of the alphanumeric keys are also supported for password and when prompted for input.

3.2.3 Connecting Terminals

The monitor utility may be accessed via the RS-232 connector located at the back of the SurfRAID LC8. The following sections describe how to configure the SurfRAID LC8 to access the monitor utility via the RS-232 port.

3.2.3.1 Communication Ports Settings

To configure the RS-232 communication ports; the following settings must be configured at the remote terminal (or terminal emulation program) and at the SurfRAID LC8.

Parameter	Value	Default Value
Baud Rate	2400, 4800, 9600, 14400, 19200, 28800, 38400, 57600, 115200	19200
Stop bits	1, 2	1
Data Bits	7, 8	8
Parity	None, Odd, Even	None
Flow Control	Software Flow Control (XON/XOFF)	Enabled

3.2.3.2 Terminal Access

To access the monitor utility, connect (a female DB-9 to female DB-9 Null Modem cable is included) the remote ANSI/VT-100 terminal or terminal emulation program to the RS-232 port located at the back of the SurfRAID LC8 subsystem.

Using a PC for Terminal Emulation.

If you do not have a dedicated ANSI/VT-100 terminal, you can still use a PC with third-party communication software that supports ANSI/VT-100 terminal emulation. Most operating systems provide ANSI/VT-100 terminal emulation programs.

For example: Microsoft Windows: Terminal or Hyper terminal
(Set up as Model VT-100)

3.2.3.3 Using the Monitor Utility

To start the monitor utility, from the remote terminal (or terminal emulation program) press the [Ctrl]+[D] keys. This will invoke the Monitor Utility. Below is a sample of the Monitor Utility.

At the top is the “ Monitor Utility” title which contains the model number and firmware version of the SurfRAID LC8. At the left is the “LCD” window. The

contents displayed also appear here on the front Panel LCD screen. Below is the “Menu” window with the Main Menu options. To the right is the “OUTPUT” window that shows more verbose information about the SurfRAID LC8. At the bottom are the instructions on how to navigate using the Monitor Utility.

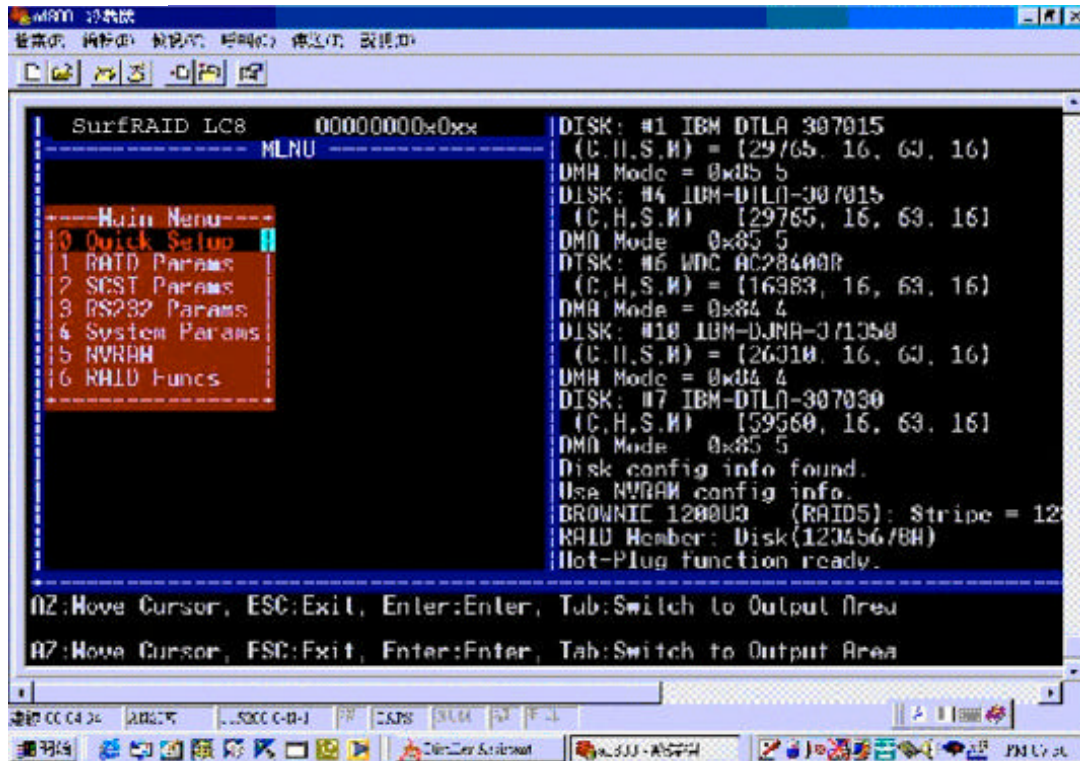

3.2.3.4 Running Configuration Mode



Configuration Mode through the monitor utility is similar to the LCD display. However, it has a graphical interface that allows for easier navigation through the menu system. Refer to section **3.3 THE SURFRAID LC8 CONFIGURATION MENU** for a detailed listing of the hierarchy of the menu system.

3.3 CONFIGURING RAID

3.3.1 Quick Setup

This is a most easy way to configure your SurfRAID LC8, but all parameters will be setup as defaults. If you want to change the default value, you have to go to customizing setup to change it.

To configure your SurfRAID LC8 via Quick setup perform the following steps:

Display	Control Panel	Terminal	Description
		Ctl-D	Invoke the Monitor Utility
SurfRAID LC8 XXXXXXXX	ENT	Tab	Go to Configuration mode
PASSWORD 0 □ □ □ □ □ □ □ □	Press “ ENT ” for 8 times	Press”0” for 8 times	Defaults Password is “00000000”
Main Menu 0 Quick Setup	ENT	Enter	Select item0 “Quick Setup”
0 Quick Setup No		A	Moving the cursor to “Yes”
0 Quick Setup Yes	ENT	Enter	Select “ Yes “
Re-Confirm No		A	Moving the cursor to “Yes”
Re-Confirm Yes	ENT	Enter	Select “Yes”
<ul style="list-style-type: none"> ● The SurfRAID LC8 will automatically restart and process the RAID initialization as RAID level 5. 			

3.3.3.1 Defaults value of Quick setup :

The RAID’s parameters will be set to defaults value (as the following table) after processing the “**Quick setup**” function. If you want to change any setting, refer to **3.3.2 Customizing Setup** to set it manually.

Parameter	Value	Description
RAID Level	5	
Disk Number	N	System will auto scan the disk numbers in RAID.
Hot Spare	No	You can add a DISK into the system as a Hot Spare Disk after the RAID completes the quick setup procedure.
SCSI ID	0	
Password	00000000	
Termination	Disabled	

3.3.2 Customizing Setup

The Configuration Menu is provided to help facilitate and assist configuring the SurfRAID LC8 RAID subsystem. The SurfRAID LC8 has to disconnect from the host system when running the Configuration Menu.

The main menu consists of seven categories. Each category is used to configure a different part of the SurfRAID LC8 subsystem. The following shows the main menu categories. Each category has sub-menus and options. In the following sections, the menu hierarchy will be described in detail.

Main Menu
0 QUICK SETUP
1 RAID Params
2 SCSI/FIBRE Params
3 RS232 Params
4 System Params
5 NVRAM
6 RAID Funcs

3.3.2.1 RAID Params MENU

RAID Params menu configures the SurfRAID LC8 for the different supported RAID levels. To avoid accidentally erasing an existing configuration you must specify, using the “11 Re-Conf RAID” option, if you want to change the configuration.

NOTE: Any changes made to **11 Re-Conf RAID, 12 RAID Level, 13 Disk Number, 14 Slice & 15 Stripe Size** will cause data on the drives to be permanently erased.

Sub-menu	Settings	Default setting
11 Re-Conf RAID	No, Yes	No
Description :	Use to change an existing RAID configuration. Only use to change RAID Level & Disk Number.	

Sub-menu	Settings	Default setting
12 RAID Level	0, 1, 3, 5, 0+1, None	None
Description :	Use to specify the RAID Level. Refer to section for a description of each RAID level.	

Sub-menu	Settings	Default setting
13 Disk Number	8,7, 6, 5, 4, 3, 2, 1	8
Description :	Use to specify the number of disks in the array. The number is based on the number of physical disks installed.	

Sub-menu	Sub-Options	Setting	Defaults
14 Slice	141 Slice0	MB	Same as RAID Capacity
	142 Slice1	MB	0
	143 Slice2	MB	0
	144 Slice3	MB	0
	145 Slice4	MB	0
	146 Slice5	MB	0
	147 Slice6	MB	0
	148 Slice7	MB	0
Description :	Use to divide the RAID capacity to several separated Slices. Maximum 8 of Slices can be set at same time.		

Sub-menu	Settings	Default setting
15 Stripe Size	128, 64, 32, 16, 8, 4	64
Description :	Use to specify the size of the stripe in blocks (1 block = 512 bytes).	

Sub-menu	Settings	Default setting
16 Write Buffer	Enable, Disable	Enable
Description :	Use to buffer write operations using memory. This helps improve the	

	write performance for RAID 5 configuration.
--	---

Sub-menu	Sub options	Settings	Default setting
17 IDE DMA Mode	171 Disk 1	0, 1, 2, 3, 4, 5	5
	172 Disk 2	0, 1, 2, 3, 4, 5	5
	173 Disk 3	0, 1, 2, 3, 4, 5	5
	174 Disk 4	0, 1, 2, 3, 4, 5	5
	175 Disk 5	0, 1, 2, 3, 4, 5	5
	176 Disk 6	0, 1, 2, 3, 4, 5	5
	177 Disk 7	0, 1, 2, 3, 4, 5	5
	178 Disk 8	0, 1, 2, 3, 4, 5	5
	179 ALL	0, 1, 2, 3, 4, 5	5
Description :	Use to negotiate the highest DMA data transfer mode with the installed disks during initialization.		

18 IDE LBA Mode	Setting	Defaults Setting
	Enable, Disable	Enable
Description :	Use to enable the LBA feature. The feature allows SurfRAID LC8 to manage large size disk.	
19 IDE Ultra DMA	Setting	Defaults Setting
	Enable, Disable	Enable
Description :	Use to enable the Ultra DMA data transfer mode of the SurfRAID LC8 with the installed disks during initialization.	
1A Performance	Setting	Defaults Setting
	Random, Sequential	Random
Description :	Use to select the mode of Data Access.	

3.3.2.2 SCSI/FIBRE Params MENU

The SCSI/FIBRE Params menu configures the SCSI/Fibre portion of the SurfRAID LC8 subsystem. The SCSI ID and the termination must be set to avoid causing a conflict with the SCSI adapter or other SCSI devices daisy chained with the SurfRAID LC8. Command Tag Queuing is a function that allows a SCSI device to queue multiple requests without having to serialize the operations. This frees the controller to process requests in whatever order is convenient, instead of blindly processing and acknowledging each disk operation before starting the next. This allows the SurfRAID LC8 to efficiently handle multithreaded applications that issue multiple disk commands.

A. LC8.160

The “SCSI Params” consists of two categories. Each category is used to configure an independent SCSI channel of the SurfRAID LC8 subsystem. The following shows both categories. Each category has sub-menus and options.

2. SCSI Param
21 Primary SCSI
22 Secondary SCSI

Sub-menu option	Settings	Default setting
211 & 222 Set SCSI ID	0, 1, 2, 3, 4, 3, 4, 5, 6, 7, 8, 9, 10, 11, 12, 13,14, Multiple	0
Description :	Use to specify the SCSI ID for the SurfRAID LC8.	

Sub-menu option	Settings	Default setting
212 & 222 Termination	Enable, Disable	Disable
Description :	Use to enable the SCSI termination of the SurfRAID LC8.	

Sub-menu option	Settings	Default setting
213 & 223 TAG Queuing	Enable, Disable	Enable
Description :	Use to enable the SCSI Tag Queuing feature. This feature allows the handling of more I/O requests from the host improving the performance of the SurfRAID LC8.	

Sub-menu option	Setting	Defaults Setting
214 & 224 Speed	Ultra3, Ultra2, Ultra-Fast	Ultra3
Description :	Use to enable the Ultra-SCSI feature. This feature allows to increasing the I/O speed on host Interface from Fast-SCSI to Ultra-SCSI.	

Sub-menu option	Setting	Defaults Setting
215 & 225 Wide	Enable, Disable	Enable
Description :	Use to enable the Ultra/Fast Wide SCSI feature. This feature allows to increasing the I/O speed on host Interface from SCSI to Wide SCSI.	

Sub-menu option	Sub-options	Setting	Defaults
216 & 226 Lun Map	2161 Lun 0	Slice 0,1,2,3,4,5,6,7& Disable	Slice 0
	2162 Lun 1	Slice 0,1,2,3,4,5,6,7& Disable	Slice 0
	2163 Lun 2	Slice 0,1,2,3,4,5,6,7& Disable	Slice 0
	2164 Lun 3	Slice 0,1,2,3,4,5,6,7& Disable	Slice 0
	2165 Lun 4	Slice 0,1,2,3,4,5,6,7& Disable	Slice 0
	2166 Lun 5	Slice 0,1,2,3,4,5,6,7& Disable	Slice 0
	2167 Lun 6	Slice 0,1,2,3,4,5,6,7& Disable	Slice 0
	2168 Lun 7	Slice 0,1,2,3,4,5,6,7& Disable	Slice 0
Description :	Use to setup each Slice to map a logical Lun Number.		

B. LC8.200

The “FIBRE Params” consists of two categories. Each category is used to configure an independent FC-AL of the SurfRAID LC8 subsystem. The following shows the both categories. Each category has sub-menus and options.

2. FIBRE Param
21 Primary FC-AL
22 Secondary FC-AL

Sub-menu option	Settings	Default setting
211 & 221 Hard Loop	Enable, Disable	Disable
Description :	“ Disable” is automatically FC-AL ID assignment. “ Enable “ is manually FC-AL ID assignment via Sun-manu 212 & 222	

Sub-menu option	Settings	Default setting
212 & 222 ID Setup	0 to 125	0
Description :	To assign the FC-AL ID # when “Hard Loop” is enable.	

Sub-menu option	Sun-options	Setting	Defaults
216 & 226 Lun Map	2161 Lun 0	Slice 0,1,2,3,4,5,6,7& Disable	Slice 0
	2162 Lun 1	Slice 0,1,2,3,4,5,6,7& Disable	Slice 0
	2163 Lun 2	Slice 0,1,2,3,4,5,6,7& Disable	Slice 0
	2164 Lun 3	Slice 0,1,2,3,4,5,6,7& Disable	Slice 0
	2165 Lun 4	Slice 0,1,2,3,4,5,6,7& Disable	Slice 0
	2166 Lun 5	Slice 0,1,2,3,4,5,6,7& Disable	Slice 0
	2167 Lun 6	Slice 0,1,2,3,4,5,6,7& Disable	Slice 0
	2168 Lun 7	Slice 0,1,2,3,4,5,6,7& Disable	Slice 0
Description :	Use to setup each Slice to map a logical Lun Number.		

3.3.2.3 RS232 Params MENU

The RS232 Params menu configures the external ports of the SurfRAID LC8. The SurfRAID LC8 can communicate with a remote terminal and modem. The SurfRAID LC8 and the remote terminal must be set to the same communication settings (baud rate, stop bit, data bit, and parity).

Sub-menu options	Sub options	Settings	Default setting
31 Modem Port	311 Baud Rate	2400, 4800, 9600, 14400, 19200, 28800, 38400, 57600, 115200	38400
	312 Stop bit	1, 2	1
	313 Data bit	7, 8	8
	314 Parity	None, Odd, Even	None
Description :	Use to specify the communication protocol between the SurfRAID LC8 and external modem.		

Sub-menu options	Sub options	Settings	Default setting
32 Terminal Port	321 Baud Rate	2400, 4800, 9600, 14400, 19200, 28800, 38400, 57600, 115200	19200
	322 Stop bit	1, 2	1
	323 Data bit	7, 8	8
	324 Parity	None, Odd, Even	None
Description :	Use to specify the communication protocol between the SurfRAID LC8 and remote terminal or terminal emulation software. The settings on the remote terminal must match the settings of the SurfRAID LC8.		

3.3.2.4 SYSTEM Params MENU

The System Params menu configures the internal operation of the SurfRAID LC8. To avoid having the configuration altered by unauthorized personnel, you can enable password protection to enter Configuration Mode. Also, to have the SurfRAID LC8 provide failure event notification use the Pager Info., FAX Info, and Company Info options. The Pager and FAX features require a modem to be attached to the modem port.

Sub-menu options	Sub options	Settings	Default setting
41 Passwd Info	411 Passwd Check	Disable, Enable	Disable
	412 Set Passwd	up to 8 characters	00000000
Description :	Use to enable requiring a password when entering Configuration Mode. Use Set Passwd to change the default password.		

Sub-menu options	Sub options	Settings	Default setting
42 Pager Info	421 Paging	Disable, Enable	Disable
	422 Pager1 No.	Enter the pager number to notify	
		4221 Tel No.	16 characters
		4222 Pin No.	16 characters
	423 Pager2 No.	Enter the pager number to notify	
		4231 Tel No.	16 characters
		4232 Tel No.	16 characters
	424 Code	Enter the code displayed on the pager	
		4241 Part 1.	16 characters
		4242 Part 2.	12 characters
	425 Repeat #	20, 15, 10, 5	5
	426 Interval	20, 15, 10, 5	5
	427 Page NOW	None	none
Description :	Use to enable paging notification when a failure occurs. One or two pagers can be notified with a unique code that can be up to 28 characters. For each pager you can enter the telephone number and pin number (if required). The pager(s) can be notified up to 20 times at intervals (in minutes) of up to 20 minutes. Use the Page NOW option to immediately send a page.		

Sub-menu options	Sub options	Settings	Default setting
43 FAX Info	431 FAX	Disable, Enable	Disable
	432 FAX Class	2, 1	1
	433 FAX1 No.	up to 16 numbers	
	434 FAX2 No.	up to 16 numbers	
	435 Retry #	20, 15, 10, 5	5
	436 FAX NOW	None	none
Description :	Use to enable fax notification when a failure occurs. One or two fax stations can be notified. Use the FAX Class to specify the fax class support of the modem. The fax can be sent up to 20 times at intervals (in minutes) of up to 20 minutes. Use the FAX Now option to immediately send a fax.		

Sub-menu options	Sub options	Settings
44 Company Info :	String 1	up to 16 alphanumeric characters
	String 2	up to 16 alphanumeric characters
Description :	This information will appear at the top of the fax document.	

Sub-menu options	Sub options	Settings
------------------	-------------	----------

45 Modem Init St	AT&D0&K4E0	Default initialization string for modem.
Description :	Use to change the initialization command for the modem. Change this option if the default string does not work with your modem.	

3.3.2.5 NVRAM

The NVRAM menu options control the configuration information. When using this menu option, the SurfRAID LC8 should be off-line. **NOTE:** Any changes made in this group will cause data on the drives to be permanently erased.

Once a configuration change has been made, the NVRAM (where the settings are stored) must be updated. If a change causes an error or if the subsystem fails, use the “Erase NVRAM” option to clear the contents of NVRAM restoring the default values. In order for a change to take effect, the SurfRAID LC8, subsystem must be restarted. Use the Restart option to automatically reset the SurfRAID LC8 subsystem.

Sub-menu options	Settings	Default setting
51 Update NVRAM	No, Yes	No
Description :	Use to store the settings for all the options. When a change is made in order for it to take effect, it must be saved in NVRAM.	

Sub-menu options	Settings	Default setting
52 Erase NVRAM	No, Yes	No
Description :	Use to clear the contents of NVRAM and restore the default settings.	

Sub-menu options	Settings	Default setting
53 Restart	No, Yes	No
Description :	Use to reset the SurfRAID LC8. Use this option after changing any settings to allow them to take effect.	

3.3.2.6 RAID Funcs MENU

The RAID Funcs menu allows different functions to be performed on the SurfRAID LC8. **NOTE:** Any changes made to **61 Format Disk**, **62 Init RAID 5**, **63 R5 Check** will cause data to be permanently erased on the disks.

Sub-menu	Sub options	Settings	Default setting
61 Format Disk	611 Format Disk1	Stop, Start	Stop
	612 Format Disk2	Stop, Start	Stop
	613 Format Disk3	Stop, Start	Stop
	614 Format Disk4	Stop, Start	Stop
	615 Format Disk5	Stop, Start	Stop
	616 Format Disk6	Stop, Start	Stop
	617 Format Disk7	Stop, Start	Stop
	618 Format Disk8	Stop, Start	Stop
	619 Format ALL	Stop, Start	Stop
Description :	Use to low-level format the disks. This option is only available when the SurfRAID LC8 is not configured. This option is not mandatory but optional. Most new disks do not require a low-level format. Use only if drive is exhibiting problems.		

Sub-menu options	Settings	Default setting
62 Init R5/R3	Stop, Start	Stop
Description :	Use when configuring a disk group for RAID Level 5. During an initial RAID 5 configuration, this is automatically executed.	

Sub-menu options	Settings	Default setting
63 R5/R3 Check	Stop, Start	Stop
Description :	Use to verify the RAID 5 configuration. This option should be executed when initially configuring for RAID 5.	

Sub-menu options	Settings	Default setting
64 Beeper	Clear, Enable, Disable	Enable
Description :	Use to turn on or off the audible alarm when an error occurs or during an Init RAID 5, R5 Check.	
Sub-menu options	Settings	Default setting
65 Stop Modem	No, Yes	No
Description :	Use to stop a Page or FAX notification from being sent. Use to stop receiving the same Page or FAX notification after the initial one has been acknowledged.	

Sub-menu options	Settings	Default setting
66 Add Disk	Disk 1	none
	Disk 2	none
	Disk 3	none
	Disk 4	none
	Disk 5	none
	Disk 6	none
	Disk 7	none
	Disk 8	none
Description :	Use this option to add a disk to an existing configuration. This is only valid when an existing disk was removed using the 67 Remove Disk option.	

Sub-menu options	Settings	Default setting
67 Remove Disk	Disk 1	None
	Disk 2	None
	Disk 3	None
	Disk 4	none
	Disk 5	none
	Disk 6	none
	Disk 7	none
	Disk 8	none
Description :	Use this option to remove a disk from an existing configuration. This allows the safe shutdown of a potential faulty disk. The drive will be removed from the configuration and the spare drive (if available) will automatically be added. Once the drive has been removed, use the Add Disk option to add the new drive to the configuration.	

Sub-menu options	Settings	Default setting
68 Statistic	None	None
Description :	Use this to view the current settings saved in NVRAM, get a statistical analysis of the read and write operations, plus the percentage of cache hits. This information is only viewable using the Monitor Utility via the RS-232 port.	

Sub-menu options	Sub options	Settings
69 Expand Array	691 1 Disk	No, Yes







	692 2 Disks	No, Yes
	693 3 Disks	No, Yes
	694 4 Disks	No, Yes
	695 5 Disks	No, Yes
	696 6 Disks	No, Yes
	697 7 Disks	No, Yes
Description :	Use this option to increase the disk numbers to an existing configuration. This feature can increase the array's capacity.	

Sub-menu options	Settings	Default setting
6A Update ROM	none	None
Description :	Use this option to update the firmware of the SurfRAID LC8. This option should only be executed when the SurfRAID LC8 is off-line.	

3.4 SAMPLES

3.4.1 Sample1. RAID 5 with hot spare disk

Following below steps to configure your SurfRAID LC8 as RAID Level 5 with one of Hot Spare Disk.

LCD Display	Control Panel	Terminal	Description
		Ctl-D	Invoke the Monitor Utility
SurfRAID LC8 XXXXXXXXXXXX[]	ENT	Tab	Go to Configuration mode
PASSWORD 0 [] [] [] [] [] [] []	Press“ ENT ” for 8 times	Press"0" for 8 times	Defaults Password is "00000000"
Main Menu 0 Quick Setup		Z	Moving cursor to "1 RAID Params"
Main Menu 1 RAID Params	ENT	Enter	Enter to "1 RAID Params" Menu
1 RAID Params 11 Re-Conf RAID	ENT	Enter	Select "Re-Conf RAID" to re configure the RAID.
11 Re-Conf RAID No		A	Moving the cursor to "Yes"
11 Re-Conf RAID Yes	ENT	Enter	Yes. To re-configure the RAID
1 RAID Params 11 Re-Conf RAID		Z	Moving the cursor to "12 RAID Level"
1 RAID Params 12 RAID Level	ENT	Enter	Select "12 RAID Level" to setup RAID Level.
12 RAID Level None		Z	Moving the cursor to "5"
12 RAID Level 5	ENT	Enter	To confirm RAID Level is RAID 5.
1 RAID Params 12 RAID Level		Z	Moving the cursor to "13 Disk Number"
1 RAID Params 13 Disk Number	ENT	Enter	Select "13 Disk Number" to setup Disk Number in the RAID.
13 Disk Number 12		Z	Moving the cursor to "n". "n"= the numbers of disk in RAID minus 1 (for spare)
13 Disk Number "n"	ENT	Enter	To confirm the numbers of disk in RAID.
1 RAID Number	ESC	ESC	Exit to Main Menu







13 Disk Number			
Main Menu 0 Quick Setup	↓	Z	Moving the cursor to “ 2 SCSI Params”
Main Menu 2 SCSI Params	ENT	Enter	Enter to “ 2 SCSI Params” Menu
2 SCSI Params 21 Primary SCSI	ENT	Enter	Select “ 21 Primary SCSI ” to configure the Primary SCSI
21 Primary SCSI 211 Set SCSI ID	ENT	Enter	Select “ 211 Set SCSI ID “ to set SCSI number of Primary SCSI Channel.
211 Set SCSI ID 0	↓	Z	Moving the cursor to “n”. “n” = The SCSI ID what you want to setup in RAID.
211 Set SCSI ID “n”	ENT	Enter	To confirm the SCSI ID number.
2 Interf Params 21 Set SCSI ID	ESC	ESC	Exit to Main Menu
Main Menu 0 Quick Setup	↓	Z	Moving the cursor to “ NVRAM” Menu
Main Menu 5 NVRAM	ENT	Enter	Enter to “NVRAM” Menu.
5 NVRAM 51 Update NVRAM	ENT	Enter	To select “51 Update NVRAM” to update the configuration data.
51 Update NVRAM No	↓	Z	Moving the cursor to “Yes”.
51 Update NVRAM Yes	ENT	Enter	Confirm to write configuration data into NVRAM.
5 NVRAM 51 Update NVRAM	↓	Z	Moving the cursor to “ 53 Restart”
5 NVRAM 53 Restart	ENT	Enter	To restart the RAID with new configuration.
The SurfRAID LC8 will auto restart and process the RAID initial as the configuration. It will take 30 minutes to many hours (depends on the disk number and capacity) to complete the process.			
SurfRAID LC8 0000000S			The LCD will display the status as left. “0” : Disk is on-line, “S” : Disk is spare.

3.4.2 Sample 2. Change the password of your RAID

You may change some of parameters after the RAID has successfully installed the data. To avoid the data loss, please do not make any change to **11 Re-Conf RAID, 12 RAID Level, 13 Disk Number, 14 Slice, 15 Stripe Size, 52 Erase NVRAM, 61 Format Disk, 62 Init RAID 5 & 63 R5 Check**, all of them will cause data on the drives to be permanently erased.

Following is the procedure for change the password

LCD Display	Control Panel	Terminal	Description
		Ctl-D	Invoke the Monitor Utility
SurfRAID LC8 0000000S	ENT	Tab	Go to Configuration mode

PASSWORD 0 □ □ □ □ □ □ □ □	Press “ ENT ” for 8 times	Press’0” for 8 times	Defaults Password is “00000000”
Main Menu 0 Quick Setup		Z	Moving cursor to “3 System Params”
Main Menu 3 System Params	ENT	Enter	Enter to “3 System Params” Menu
3 System Menu 41 Passwd Info	ENT	Enter	Enter to “ 41 Passwd Info” sub- menu
41 Passwd Info 411 Passwd Check	ENT	Enter	Select “411 Passwd Check”
411 Passwd Check Disable		Z	Moving the cursor to “Enable”
411 Passwd Check Enable	ENT	Enter	Confirm to setup “411 Passwd Check” function as Enable.
41 Passwd Info 411 Passwd Check		Z	Moving the cursor to ”412 Set Passwd”
41 Passwd Info 412 Set Passwd	ENT	Enter	Select “412 Set Passwd” to setup new Password.
412 Sep Passwd 0□□□□□□□	 & Enter, for 8 of digital numbers	8 of digital numbers	Enter your new password by 8 of digital numbers. Defaults is “00000000”
41 Passwd Info 412 Set Passwd	ESC	ESC	Exit “412 Set Passwd” to “41 Passwd”
4 System Params 41Passwd Info	ESC	ESC	Exit “41 Passwd Info” to Main Menu.
Main Menu 4 System Params		Z	Moving the cursor to “ 5 NVRAM
Main Menu 5 NVRAM	ENT	Enter	Enter to “NVRAM” Menu.
5 NVRAM 51 Update NVRAM	ENT	Enter	To select “51 Update NVRAM” to update the configuration data.
51 Update NVRAM No		Z	Moving the cursor to “Yes”.
51 Update NVRAM Yes	ENT	Enter	Confirm to write configuration data into NVRAM.
5 NVRAM 51 Update NVRAM		Z	Moving the cursor to “ 53 Restart”
5 NVRAM 53 Restart	ENT	Enter	To restart the RAID with new configuration.
* If you want to enter to configuration mode after RAID start up, you have to use the new password.			

CHAPTER 4. Hot Swap Components

The SurfRAID LC8 supports hot-swappable disk cartridges, power supply modules and cooling fan unit. The following sections describe how to use the hot swap feature.

4.1 Swapping the Disk

To hot swap a disk, perform the following steps (Refer to 2.5.2 Installing the disk).

1. Slide the latch to the position of unlock.
2. Open the cartridge handle by sliding the release button and wait for the drive to spin down (The disk LED on the drive bay will turn from green to red indicate the disk is powered down.).
3. Lift the handle to disengage the disk cartridge from the slot.
4. Gently pull the disk cartridge out of the slot.
5. Replace the HDD.
6. Holding the cartridge handle, insert the cartridge into the bay along the plastic guides until the handle begins to close.
7. Push down the handle to secure the cartridge into the SurfRAID LC8 system.
8. Slide the latch to the position of lock.

The drive is now replaced. Once the drive has powered on, it will be added to the RAID configuration automatically.

4.2 Swapping the Power Supply Module

If the power supply has failed, the LED on front panel will turn from green to Red and the power supply buzzer will sound.

To hot swap a power supply module perform the following steps.

1. Push the reset button to stop the audible alarm on the rear panel.
 2. Unscrew the defective power module unit.
 3. Pull the handle to disengage the module from the power supply base.
 4. Slide the module out completely from the power supply base.
 5. Insert the new power supply module.
- NOTE:** Use the handle to slide the module in to the base until it engages to the base.
6. The LED will turn bright green to indicate it has powered on.



4.3 SWAPPING THE COOLING FANS

4.3.1 System Cooling Fans

If the system cooling fans module fails, the LCD on front panel will display “Fail Fan” and audible alarm will be sound.

To hot swap a system cooling fan module perform the following steps.

1. Release the thumbscrews on the fan module, the Fan fail LED on the module should turn bright red.
2. Slide the module out completely from the cooling Fan module base.
3. Replace with a new Fan module and insert it into the cooling fan module base.
4. The error message on LCD will turn to normal and the audible alarm will be stop automatically after the above processes.
5. Fasten the thumbscrews.



CHAPTER 5. ADVANCED SETUP

5.1 Updating Firmware

The embedded firmware of the SurfRAID LC8 can be updated through the RS-232 port using a terminal or PC in terminal emulation mode. When updating the firmware, make sure the SurfRAID LC8 is disconnected from the system to avoid any data loss. Verify the terminal, or terminal emulation software, settings (Baud rate, Stop bit, Data bit, Parity & etc.) to the value as shown below:

Baud Rate	19200
Data bits	8
Stop bit	1
Parity	0
File transfer protocol	Send ASCII text file
File name	File name of new reversion Firmware

To update the firmware, perform the following steps.

NOTE: Refer to section 3.2 **Monitor Utility** for more information

Message	Pressing	Description
	Ctrl-D	Invoke the Monitor utility
LC8 Monitor Utility	Tab	Go to "Configuration mode"
Password	Enter	
Password --xxxxxxxx--	Your Password by 8 digital Numbers. (Default is "00000000")	Password Control
6 RAID Params	"A" or "Z" and Enter	To select "6 RAID Params"
6A Update ROM	"A" or "Z" and Enter	To select "6A Update ROM"

Are you ready to download the firmware?	“y”	Yes. Be sure the host computer is disconnected with RAID.
Are you sure ?	“y”	Yes. * download the firmware to RAM.
Begin firmware transfer now		Display the current status.
File transfer complete Checksum=xxxx :OK. New firmware transfer complete.		Display the current status.
Enter ‘Go’ to update the firmware	Go	Update firmware from RAM to ROM
Enter ‘Go’ to reconfirm	Go	Reconfirm to update the firmware from RAM to ROM.
Programming..... Done Verifying..... Done		Display the current status.
SurfRAID LC8 will auto restart with new reversion firmware.		

APPENDIX A. TROUBLESHOOTING AND ERROR MESSAGES

A1. Troubleshooting

A. LC8.160

Problem: SurfRAID LC8 is not properly identified by the SCSI adapter during the initialization of you computer system.

Possible Cause: The SCSI ID set for the SurfRAID LC8 is used by another SCSI device attached to the same SCSI adapter.

Fix: Through the Configuration Mode select SCSI Params, then Set SCSI ID, and specify a different SCSI ID. Also, most SCSI host adapters provide an onboard ROM BIOS, or software utility, that displays the devices attached and their SCSI ID. Disconnect the SurfRAID LC8 from the SCSI host adapter. During the system boot, (or by running the utility) note the SCSI ID’s already in use. This will select a SCSI ID for the SurfRAID LC8.

Problem: The SurfRAID LC8 is identified at all SCSI ID’s.

Possible Cause: The SCSI ID set for the SurfRAID LC8 is identical to the reserved SCSI ID used by the SCSI adapter in your computer system.

Fix: Use the Configuration Mode to configure the SurfRAID LC8 for a different SCSI ID. Remember the majority of SCSI host adapter reserves SCSI ID 7 for the adapter ID.

Problem: The SurfRAID LC8 is not detected by the SCSI host adapter.

Possible Cause: Incorrect termination in a daisy chain configuration or a loose cable in a stand-alone configuration.

Fix: In a daisy chain configuration verify only the SCSI host adapter and the last SCSI device is terminated. To change the termination settings of the SurfRAID LC8 use the SCSI Params menu and SCSI Termination option to enable or disable termination.

B. LC8.200

Problem: SurfRAID LC8 is not properly identified by the FC-AL adapter during the initialization of your computer system.

Possible Cause: The FC-AL ID set for the SurfRAID LC8 is used by another device attached to the same FC-AL adapter.

Fix: Through the Configuration Mode select Interf Params, then Set FC-AL ID, and specify a different FC-AL ID. Also, most FC-AL host adapters provide an onboard ROM BIOS, or software utility, that displays the devices attached and their FC-AL ID. Disconnect the SurfRAID LC8 from the FC-AL adapter. During the system boot, (or by running the utility) note the FC-AL ID's already in use. This will select an ID for the SurfRAID LC8.

Problem: The SurfRAID LC8 is identified at all FC-AL ID's.

Possible Cause: The ID set for the SurfRAID LC8 is identical to the reserved ID used by the FC-AL adapter in your computer system.

Fix: Use the Configuration Mode to configure the SurfRAID LC8 for a different FC-AL ID.

C. LC8.160 & LC8.200

Problem: Unable to access the SurfRAID LC8 after the operating system boots up.

Possible Cause: The SurfRAID LC8 is not configured.

Fix: Make sure the SurfRAID LC8 is configured for a RAID level. If no RAID level is configured the operating system will not detect the SurfRAID LC8 as a disk drive.

Problem: Unable to access the Configuration Mode using the remote terminal interface.

Possible Cause: The terminal communications settings are not matching the settings of the SurfRAID LC8 RS-232 interface.

Fix: The default settings for the RS-232 port are 19200 Baud rate, 8 Data bits, 1 Stop bit, No Parity, and XON/XOFF Flow control. Make sure the terminal is configured for these settings. If the settings were changed during Configuration Mode verify the settings of the SurfRAID LC8 in the RS-232 Params, Terminal option and change the terminal settings accordingly.

Problem: The front panel LCD displays alternating "Zz" characters.

Cause: These characters are displayed when the cache is full with write request's data that have not been processed. It will halt requests from the host to flush the data in the cache.

Fix: None needed.

Problem: The front panel LCD displays alternating "Ww" characters.

Cause: These characters are displayed to indicate the write requests in the cache are being processed. When these characters are displayed, the SurfRAID LC8 will halt requests from the host (see above).

Fix: Make sure the "WRITE BUFFER" option of the "RAID Params" menu is enabled. In addition, more cache memory may be required. By increasing the cache memory the write buffer space increases and will be able to handle the higher write requests

Problem: Unable to send a Page or FAX using the modem port.

Possible Cause: The Page and Fax options are not enabled.

Fix: Go to the Configuration Mode and enable Page and FAX notification via the System Params menu option.

Problem: Memory test fails during Self-Test.

Possible Cause: Memory SIMM module may not be properly seated or may be defective.

Fix: Re-sit the memory module in to the socket and retry. If it continues to fail try moving it to the other memory socket. Replace the memory SIMM with another single or double-sided 144-pin SIMM.

Problem: Newly installed memory SIMM fails during Self-Test or is not detected.

Possible Cause: Memory SIMM module may not be properly seated or may not be supported by the particular SurfRAID LC8 model.

Fix: Re-sit the memory module in to the socket and retry. If it continues to fail try moving it to the other memory socket. Make sure the correct memory type is being installed. The LC8 supports SDRAM.

A2. Error Messages

The following is a listing of the error messages generated by the SurfRAID LC8 and their meaning.

Legend:	x=	Number of disk channel (1, 2, 3, 4, 5, 6, 7, 8)
	y=	Total number of disks detected by the controller
	z=	Number of disks specified in 1 RAID Params, 3 Disk Number menu option.

Error Message	Explanation
Number of disks found = y, needed = z	The number of disks found (y) does not match the number of disks configured for. The number of disks needed (z) is required.
Disk x not installed!	A disk drive (x) is not installed or is unable to be accessed.
Disk x previously removed!	A disk (x) was removed due to a failed disk or by the operator.
Too many RAID members failed!	The minimum number of disks required for the RAID configuration failed to initialize.
RAID not configured!	RAID can not be configured due to too few good disks available or no RAID configuration has been performed.
Disk x is too small!	A disk capacity being added to an existing RAID configuration is less than the configured disks. To add a disk to an existing configuration the disk must be the equal size or greater.
Disk x format ERROR!	Disk (x) failed during the format. Possible bad disk.
Init RAID5 ERROR!	The RAID 5 initialization failed. Possible bad disk. Use Disk Check to identify faulty disk.
Disk x add ERROR!	Disk (x) being added failed. Possible bad disk. Use Disk Check to identify faulty disk.
Parity ERROR: blk ? !!	A parity byte was unable to be read/write. Blk ? is the block (sector) on the disks that failed. Possible bad disk.
RAID 5 Check ERROR!	The R5 Check function failed. Possible wrong RAID configuration or not initialized (Init RAID5).
Param vendor ID ERROR!	The information in NVRAM has been erased. The configuration is lost.
Param checksum ERROR!	The information in NVRAM has been erased. The configuration is lost.
SCSI chip ERROR!	The SCSI interface of the SurfRAID LC8 controller is faulty.
Testing Serial Connection... Fail	The RS-232, Modem, or UPS port is faulty.
Do_IDE_Cmd: wait DRQ	The IDE interface is waiting for DRQ signal to go off in command phase.
Do_IDE_Cmd ERROR ? !	An error (?) occurred in IDE interface. Use Disk Check to identify faulty disk channel.
IDE_ISR: wait Master Int	IDE interface is waiting for an interrupt from a disk.
IDE_ISR: wait IDE Busy off	IDE interface is waiting for disk to be free.
IDE_ISR: status ?	IDE disk drive current status (?)
IDE_ISR: wait DRQ	To wait for disk drive to turn off DRQ in Interrupt phase.
IDE_ISR: DRQ ON	Indicates DRQ is not free in Interrupt phase.
DISK: status ?, error: ? !!	The status (status ?) and error (error: ?) returned by the disk based on the ATA-2 Specification.
DISK: #X type=?, blkno=?, resid=?	The disk (x) failed to respond to a request by the controller (type=?). The block number (blkno=?) where

	the request failed. The remaining sectors (resid=?)
DISK: Initialize #? ERROR!	The disk (x) was unable to be initialized by the controller. Possible bad disk.
DISK: #x is off-line!	Disk number (x) failed and was removed from the RAID configuration.
DISK: #x not installed!	The disk (x) is not detected by the controller. Possible bad disk.
DISK: #x ERROR status ? !	The disk (x) caused an error. The status (?) returned by the disk per ATA-2 Specification.
ERROR: Not a hard disk!	The controller does not recognize the device installed.
ERROR: Disk parameters ERROR!	The controller was unable to read the disks parameters (Cylinder, Heads, Sectors, Multi-Sector). Possible bad disk.
ERROR: No multi-sector mode!	The disk does not support the ATA-2 multi-sector transfer function. The disk is an older IDE disk.
ERROR: IORDY not support!	Disk does not support IORDY. Possible older IDE disk that does not support ATA-2 Specification. Must replace disk.
DISK: #? Remap area overflow !	The area used to re-map bad sectors is full.
DISK: #? Blk no: ? is remapped.	Block number (?) is detected as a bad sector and has been re-mapped.
DISK: #? Remap area is empty!	No re-map sectors are available while the controller detected bad sectors.
Modem time-out!	The modem did not respond to the page or FAX notification request. Modem may be turned off or not connected.
All modem operations are canceled!	User stopped the modem from sending a page or FAX notification.
Training FAIL!	Fax Class 1 support -- modem fails in training phase.
Page transfers FAIL!	The page notification failed. Modem may be turned off or not connected.
FAX: Modem is busy!	The modem is currently is use and unable to send a FAX notification.
Paging: Modem is busy!	The modem is currently is use and unable to send a page notification.
Invalid NVRAM	The information stored in the NVRAM area is invalid and unable to be used.
No Configuration	The SurfRAID LC8 is currently not configured for any RAID level.
Config ERROR	The current configuration failed to be verified. Possible fault disk or disk off-line.
Not enough Disk	Number of disks required for the RAID Level is missing. Possible faulty disks or disks off-line.

APPENDIX B. TECHNICAL SPECIFICATION

	Fibre –IDE RAID	U3 SCSI – IDE RAID
	LC8.200 Rackmount	LC8.160 Rackmount
RAID Engine	Intel i80303 64bit RISC CPU	
RAID Levels	0, 1, 3, 5 or 0+1	
Cache Support (Write back)	256Mbytes with ECC 144pins SDRAM Memory	
System Type	Rackmount	Rackmount
Host Interface	Dual Loop of 2Gbit Fibre Channel (FC-AL)	Dual Ultra 3 (Ultra 160) SCSI
Host Transfer Rate	2Gb/sec per Loop	160Mb/Sec per Channel
Disk Interface	ATA100 EIDE	
Disk Channel	Eight of UltraDMA100 Disk Channel	
Drive Bay Feature	8 Removable Units	
FC-AL ID Assignment	0-125, Software Configuration.	
SCSI ID Assignment		0 –15, Software Configuration
LCD Display	2 Lines by 16 Characters	
Hot Swap	Yes (Power Supply, Drive and Fan).	
Hot Spare	Yes (Drive).	
Select Strip Size	Yes (128, 64, 32, 16, 8 or 4 blocks) (1 block = 512 Bytes)	
Automatic Bad-Sector & Error Recovery	Yes.	
Automatic Drive Rebuilds	Yes. Automatic Data rebuilds.	
Audible Alarm, Pager and Fax Notification	Yes. The Pager and Fax Notification have to connect a external modem.	
Remote Terminal Configuration	Yes. Through RS-232 emulation terminal.	
Operating Systems	O/S Independent and Transparent	
Power Supply	Redundant by Dual 300W Power modules, Load Sharing type.	
Electrical	AC Voltage 110-230 VAC Ac Frequency 50-60Hz	
Temperature	Operating Temperature : 10 to 35 degree C.	
Relative Humidity	20% to 80% non-condensing	
Dimensions	Rackmount 482mm(W) x 570mm(D) x 3U	
Weight	15Kg(W/O Disk Drives) 18Kg	

Specification subject to change without notice. All trademarks or registered trademarks are properties of their respective owners.

APPENDIX C. CONNECTORS

* SCSI Connector

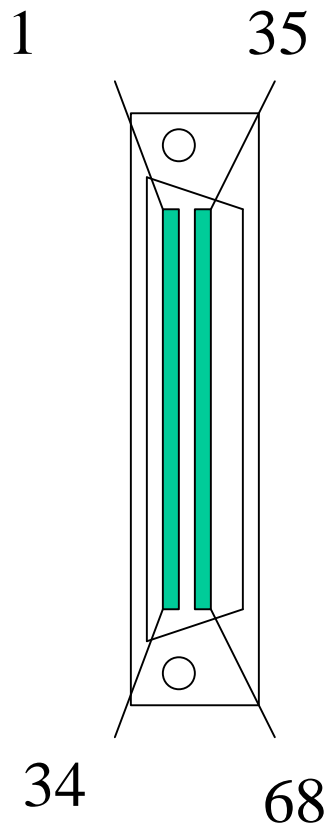

Pin#	Signal Name	Pin#	Signal Name
1	SCSI_AC_DAT<12>+	35	SCSI_AC_DAT<12>-
2	SCSI_AC_DAT<13>+	36	SCSI_AC_DAT<13>-
3	SCSI_AC_DAT<14>+	37	SCSI_AC_DAT<14>-
4	SCSI_AC_DAT<15>+	38	SCSI_AC_DAT<15>-
5	SCSI_AC_PAR<1>+	39	SCSI_AC_PAR<1>-
6	SCSI_AC_DAT<0>+	40	SCSI_AC_DAT<0>-
7	SCSI_AC_DAT<1>+	41	SCSI_AC_DAT<1>-
8	SCSI_AC_DAT<2>+	42	SCSI_AC_DAT<2>-
9	SCSI_AC_DAT<3>+	43	SCSI_AC_DAT<3>-
10	SCSI_AC_DAT<4>+	44	SCSI_AC_DAT<4>-
11	SCSI_AC_DAT<5>+	45	SCSI_AC_DAT<5>-
12	SCSI_AC_DAT<6>+	46	SCSI_AC_DAT<6>-
13	SCSI_AC_DAT<7>+	47	SCSI_AC_DAT<7>-
14	SCSI_AC_PAR<0>+	48	SCSI_AC_PAR<0>-
15	GND	49	GND
16	GND	50	GND
17	TERMPWRA	51	TERMPWRA
18	TERMPWRA	52	TERMPWRA
19	GND	53	GND
20	GND	54	GND
21	SCSI_AC_ATN_L+	55	SCSI_AC_ATN_L-
22	GND	56	GND
23	SCSI_AC_BSY_L+	57	SCSI_AC_BSY_L-
24	SCSI_AC_ACK_L+	58	SCSI_AC_ACK_L-
25	SCSI_AC_RST_L+	59	SCSI_AC_RST_L-
26	SCSI_AC_MSG_L+	60	SCSI_AC_MSG_L-
27	SCSI_AC_SEL_L+	61	SCSI_AC_SEL_L-
28	SCSI_AC_CD_L+	62	SCSI_AC_CD_L-
29	SCSI_AC_REQ_L+	63	SCSI_AC_REQ_L-
30	SCSI_AC_IO_L+	64	SCSI_AC_IO_L-
31	SCSI_AC_DAT<0>+	65	SCSI_AC_DAT<0>-
32	SCSI_AC_DAT<9>+	66	SCSI_AC_DAT<9>-
33	SCSI_AC_DAT<10>+	67	SCSI_AC_DAT<10>-
34	SCSI_AC_DAT<11>+	68	SCSI_AC_DAT<11>-

*** FC-AL 9pin D-Sub. Connector**

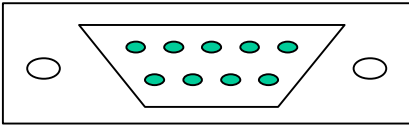

Pin#	Signal Name	Input/Output	Description
1	TX+	Output	Differential Data Output Plus
2	N/A	N/A	Unused
3	N/A	N/A	Unused
4	N/A	N/A	Unused
5	RX+	Input	Differential Data Input Plus
6	TX-	Output	Differential Data Output Minus
7	N/A	N/A	Unused
8	N/A	N/A	Unused
9	RX-	Input	Differential Data Input Minus
	Shield		Metal Shell of Connector

*** RS-232 & Modem Male Connector**

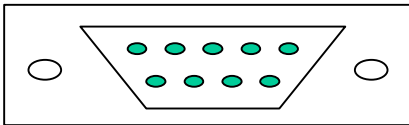

Pin#	Signal	Pin#	Signal
1	DCD	6	DSR
2	RXD	7	RTS
3	TXD	8	CTS
4	DTR	9	TXC
5	GND		

APPENDIX D. GLOSSARY

Array Management Software, Firmware

The body of software that provides common control and management for a disk array. *Array Management Software* most often executes in a disk controller or intelligent host bus adapter, but may also execute in a host computer. When it executes in a disk controller or adapter, *Array Management Software* is often referred to as Firmware.

Disk Array

A collection of disks from one or more commonly accessible disk subsystems, combined with a body of *Array Management Software*. *Array Management Software* controls the disks and presents them to the array's operating environment as one or more virtual disks.

Disk Striping

Data distributed across all the disks in the array. There is no redundant information generated or stored.

Disk Mirroring

Data is duplicated on different sets of disks in the array.

FC-AL

Fibre Channel Arbitrated Loop

Host Computer

Any computer system to which disks are directly attached and accessible for I/O. Mainframes, and servers, as well as workstations and personal computers, can all be considered host computers in the context of this book, as long as they have disks attached to them.

Hot Spare

The substitution of a replacement unit in a disk system for defective one, where the substitution can be performed while the subsystem is running.

Hot Swap

The substitution of a replacement unit in a disk subsystem for a defective one, where the substitution can be performed by the subsystem itself while it continues to perform its normal function. Hot Swaps do not require human intervention (i.e., hot spare)

Member Disks

Disk channels configured for a particular RAID Level. Member disks are identified by a status of "0" displayed on the front panel LCD.

Mirroring

A form of RAID in which *Array Management Software* maintains two or more identical copies of data on separate disks.

MTBF

An abbreviation for *Mean Time Between Failure*, the average time from start of use to failure in a large population of identical components or devices.

RAID

A *Redundant Array of Independent Disks* (RAID or RAID array) is a disk array in which part of the storage capacity is used to store redundant information about user data stored on the remainder of the storage capacity. The redundant information enables regeneration of user data in the event that one of the array's member disks or the access path to it fails.

RAID levels

The original RAID level 1 through 5 was outlined in a research paper entitled *A Case for Redundant Arrays of Inexpensive Disks*. This paper was published in 1988 by David A. Patterson, Garth Gibson, and Randy H. Katz of the University of California at Berkley. Counting the term RAID 0 that refers to disk striping and later defined RAID 6, there are 7 levels of RAID.

SCSI

Small Computer System Interface.

SCSI ID

Also called SCSI ID#, is an octal representation of the unique address assigned to a SCSI device.

Spare, Spare Disk

A disk reserved for substitution of a like entity in case of the failure of that entity.

Swap

The replacement of a defective unit with a new unit. Units are parts of a disk subsystem that may either be field replaceable by a vendor service representative or consumer replaceable.

Appendix E. Creating Two LUN's on the SurfRAID LC8

- 1) Build RAID as required (RAID 1, 3, 5...)
- 2) Enter Main Menu, First Select: RAID Parameters, Second Select: Slice, Third Select: Slice0. You will now see the whole size of your RAID system in (MB)
- 3) Enter disk size for Slice0 (for example 100000 MB)
- 4) Enter disk size for Slice1 (for example 33622 MB, then press Enter)
- 5) When you are done entering the disk size for the Slice, you will need to update the NVRAM. Go to Main Menu and NVRAM and select Update NVRAM, Select YES.
- 6) Return to the Main Menu, Select: SCSI Parameters, Select Primary SCSI/FC and then LUN Map.
- 7) Select Lun 0 mapping to Slice 0.
- 8) Return to the Main Menu, Select: SCSI/FC Parameters, Select Secondary SCSI/FC and then Lun Map.
- 9) Select Lun 0 mapping to Slice 1.
- 10) After Lun mapping you will need to update the NVRAM again, Go to Main Menu and NVRAM and select Update NVRAM, Select YES.
- 11) You will now need to restart the system. Go to Main Menu, Select NVRAM, then Restart, then Yes.
- 12) After restarting, you will get Primary SCSI mapping to Slice0, Secondary SCSI/FC mapping to Slice 1
 - a) Primary SCSI/FC (Slice 0 = 100000 MB) example.
 - b) Secondary SCSI/FC (Slice 1 = 33622 MB) example.

APPENDIX E. FIBRE RAID TO HOST CONNECTIVITY

SurfRAID LC8

SET 2x1 Enable Hard Loop ID to ENABLE
 SET 2x2 Set Hard Loop ID to (0~125)

Set Data Rate 2x4
1GB/S
2GB/S

QLA2300

Set same Data Rate on SurfRAID LC8
 Do not set to Auto Select

Data Rate
0 – 1GB/S
1 – 2GB/S

2 - Auto Select

^---using Auto Select may be unstable

SurfRAID LC8		QLA2300		Bios		Windows 2000	
				Primary FC	Secondary FC	Primary FC	Secondary FC
Data Rate	Connection Mode	Data Rate	Connection Mode				
1 GB	Arbitrated Loop	1 GB/S	Dual Loop preferred, otherwise Point to Point	OK	OK	OK	OK
1 GB	Point-to-Point	1 GB/S	Dual Loop preferred, otherwise Point to Point	OK	OK	OK	OK
2 GB	Arbitrated Loop	2 GB/S	Dual Loop preferred, otherwise Point to Point	OK	OK	OK	OK
2 GB	Point-to-Point	2 GB/S	Dual Loop preferred, otherwise Point to Point	OK	OK	OK	OK

If the SurfRAID LC8 is set to Auto-Select and the QLA2300 is set to Auto Select the solution will be unstable.

SurfRAID LC8		SUN Blade 1000 on Board Fibre		OBP		Solaris 8	
Data Rate	Connection Mode	Data Rate	Connection Mode	Primary FC	Secondary FC	Primary FC	Secondary FC
1GB	Arbitrated Loop	1 GB/S	Arbitrated Loop only.	OK	OK	OK	OK
1GB	Point-to-Point	2 GB/S	Do not set Point-to-Point	OK	OK	OK	OK

If you add an HBA to a Sun Blade 1000/2000 or Sun Fire 280R, you will need to set the Data Rate and Connection Mode alike under the BIOS. Reference the Fibre Channel Host Adapter Installation Guide under the settings prompt.